



# Yealink T58W

Avatel Cloud Solution  
User Guide

Version 1.1

# Front View

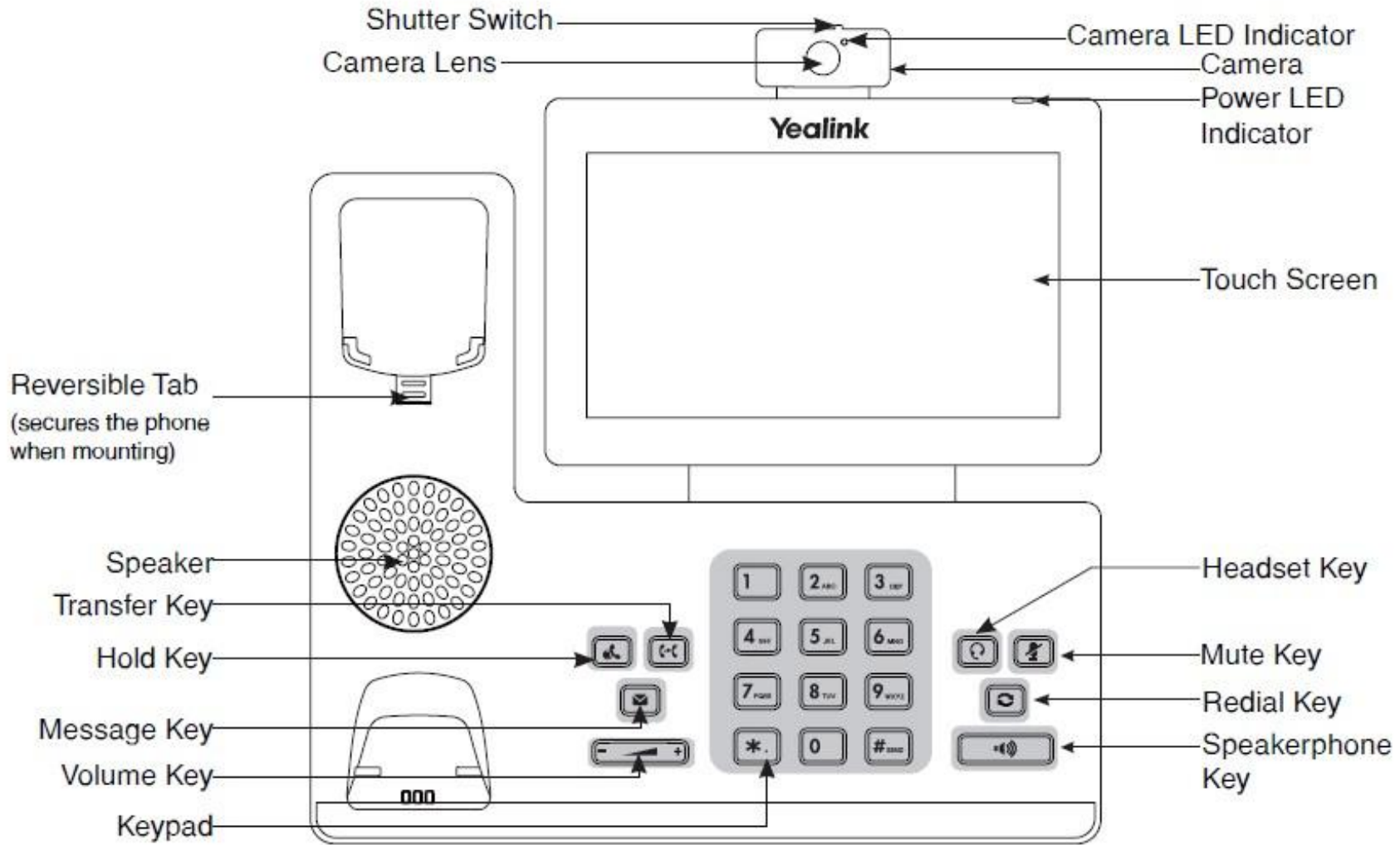

# Rear View

USB2.0 Port

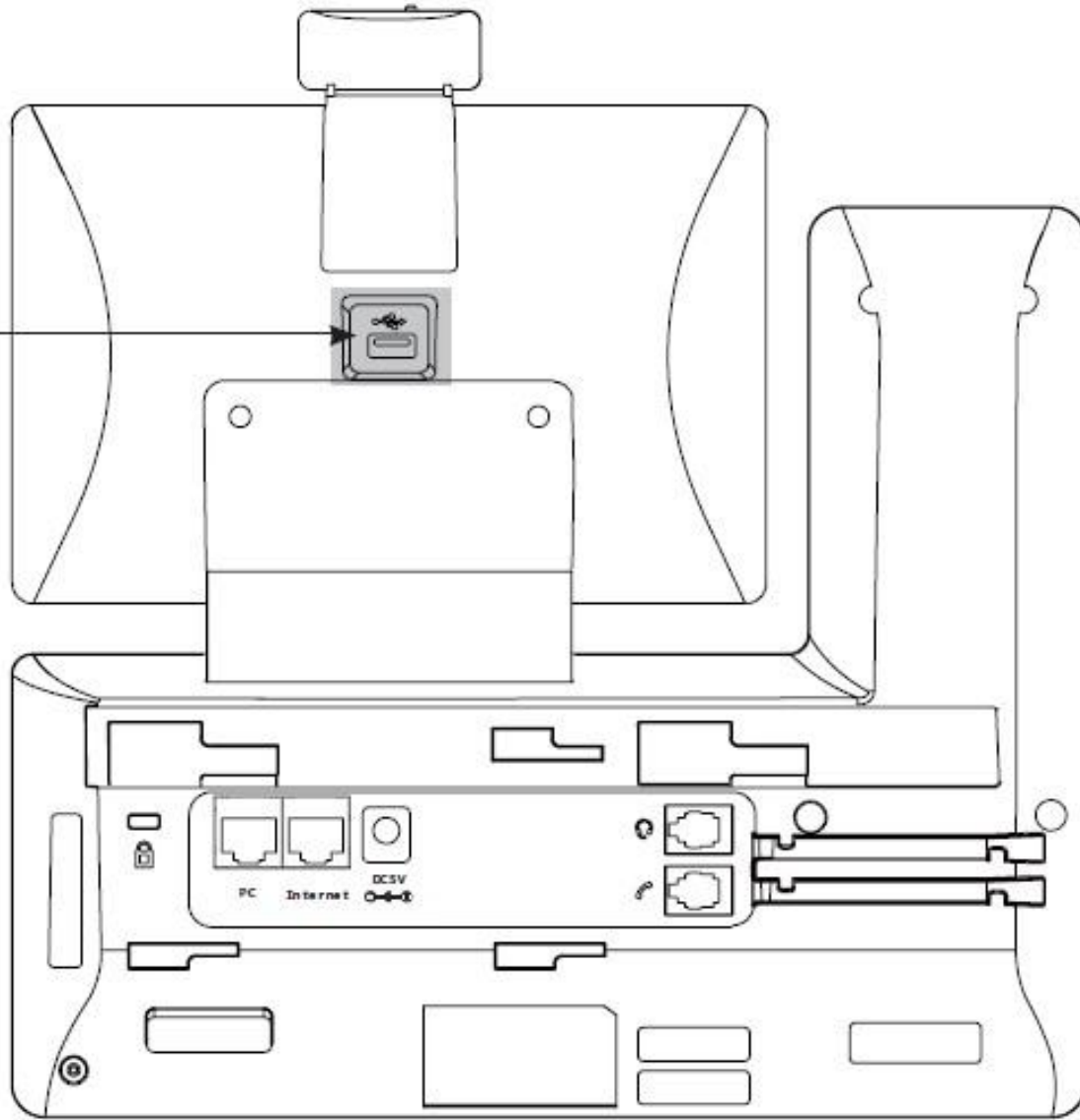



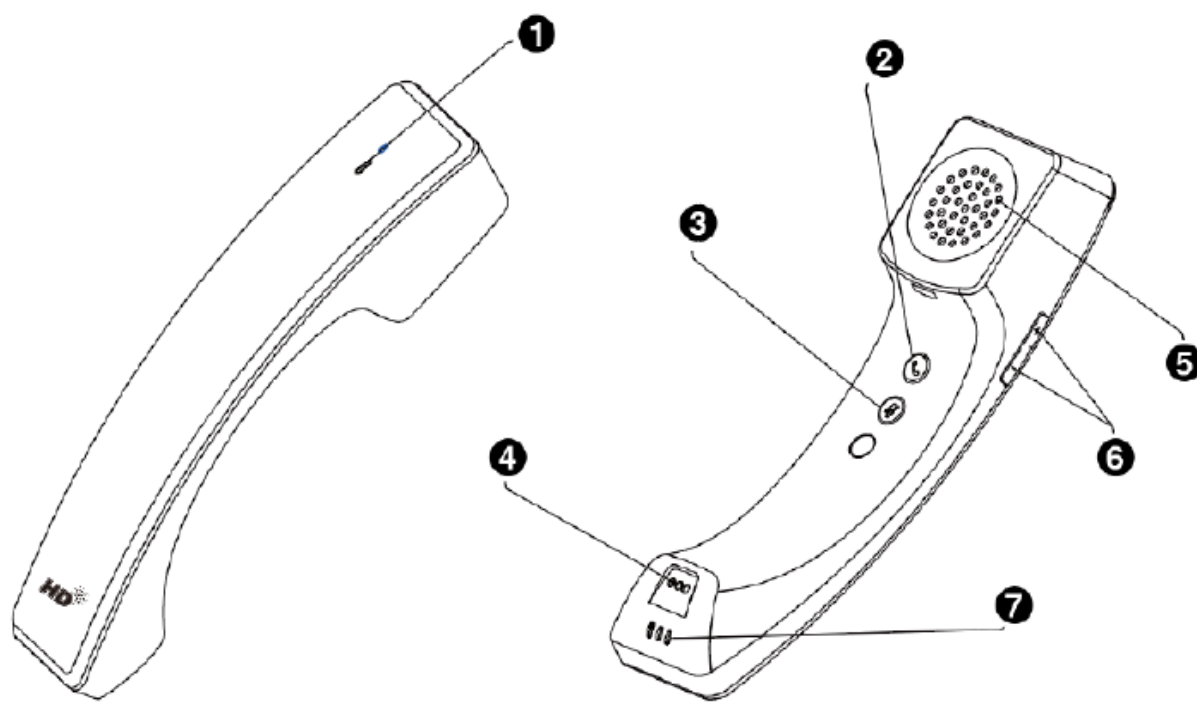

























# BlueTooth Handset



























No.	Item	Description
1	LED Indicator	Indicates handset statuses.
2	Hookswitch Key	<ul style="list-style-type: none"><li>• Answer/Reject/Hang up a call.</li><li>• Long press 3s to power on the handset.</li><li>• Long press 8s to power off the handset.</li></ul>
3	Mute Key	Toggles and indicates the mute feature.
4	Microphone	Provides audio input during calling.
5	Speaker	Provides audio output during calling.
6	Volume Control Keys	Adjust the volume of the handset and the phone.
7	Charging Contacts	Place the handset on the phone handset cradle, the handset starts charging.

# Status Indicator Icons

Icons	Description	Icons	Description
	Wired network is unavailable		Bluetooth mode is on
	Speakerphone (hands-free) mode		Bluetooth headset is both paired and connected
	Handset mode		Bluetooth-enabled mobile phone paired and connected
	Headset mode		Wi-Fi mode is on
	Voice Mail		Wi-Fi signal strength from weak to strong after connecting successfully
	Auto Answer		The USB flash drive is detected
	Do Not Disturb (DND)		Screenshot captured
	Keep Mute		Downloading file
	Silent Mode		Uploading file
	Phone Lock		Upcoming alarm
	Missed Calls		Unread email

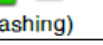
Icons	Description	Icons	Description
	Always Forward		Phone Warning
	No Answer Forward		PSTN box is detected
	Busy Forward		Wireless Access Point

Icons	Description	Icons	Description
	Hold		DND
	Voice Mail		SMS
	Direct Pickup		Group Pickup
	Conference		Forward
	Transfer		Recall
	Record		Recording in process
	Multicast Paging Paging List		Hot Desking
	Phone Lock		Directory
	Speed Dial		DECT Intercom

Icons	Description	Icons	Description
	The private line registers successfully.		The shared/bridged line registers successfully.
	Registering.		Register failed.
	DND is enabled on this line.		Call forward is enabled on this line.

# DeskPhone Functions

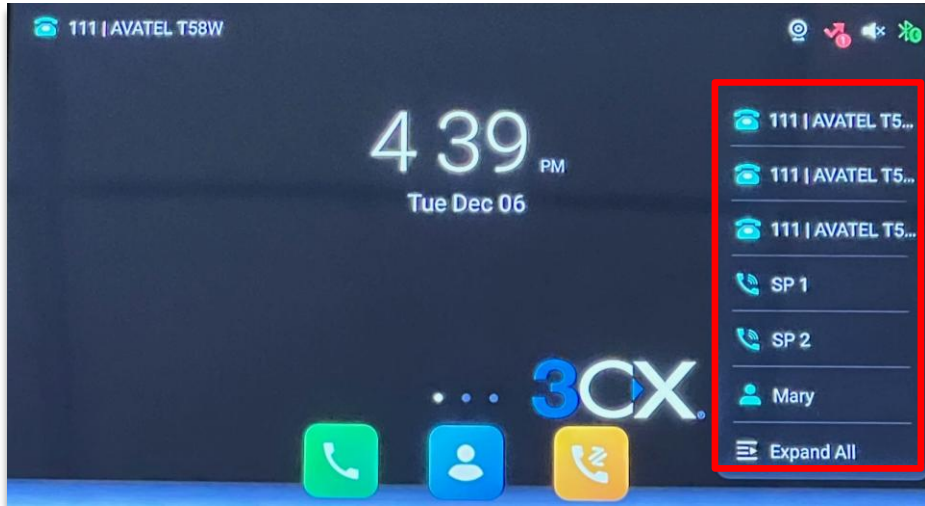

**DSS Keys** are keys on the phone which are typically used for displaying other extensions in the office and their status or functions such as page or parks keys. As an example, other users on a call will be red instead of green, indicating the phone is in use. They can also be used for transferring calls or calling internally.

Your Extension number

Phone Status Icons

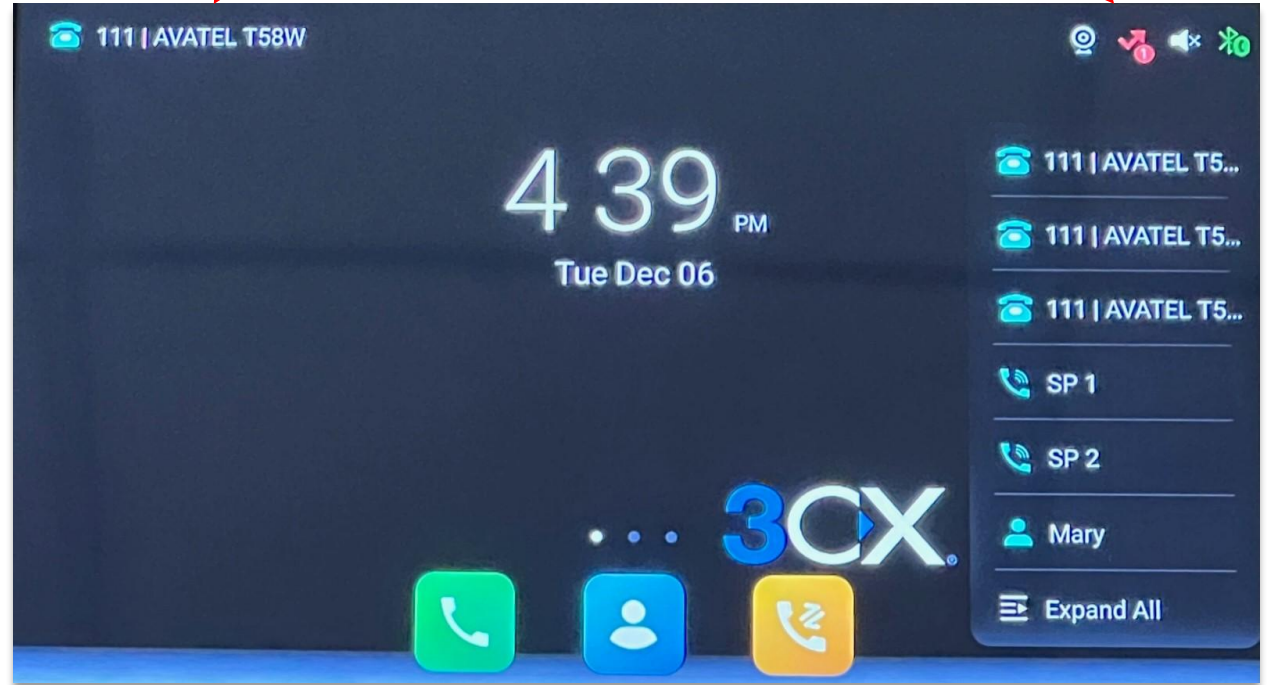

Call

Contacts

History



# Voicemail Status Indicator

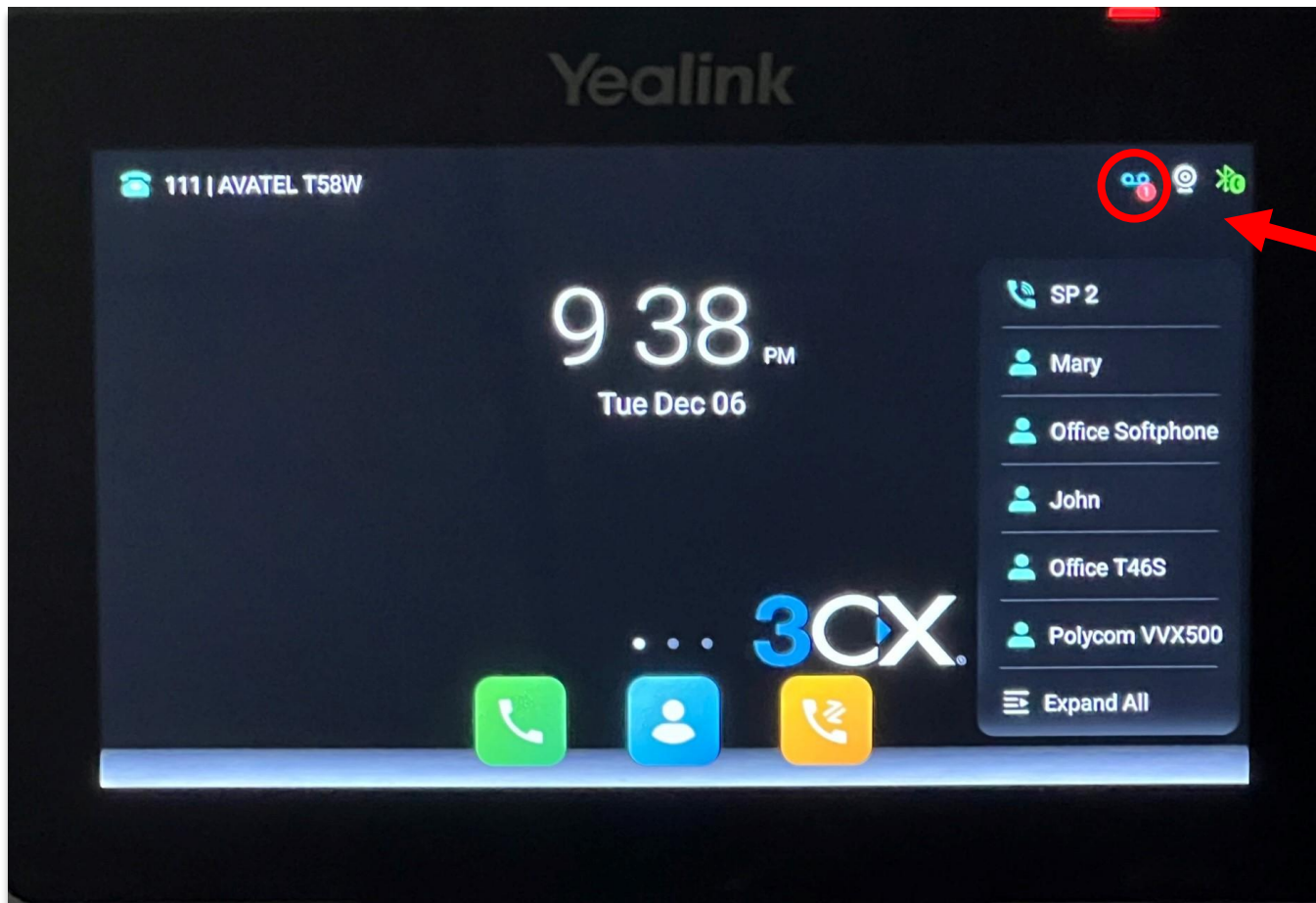

## Voicemail Status Indicator LED

The top section of the handset screen will display the status of voicemail. The LED lamp will light red when a message is left in your voicemail box.

## Voicemail Status Icon

The top right-hand section of the screen displays the phone status icons, including the number of voicemails in your inbox.

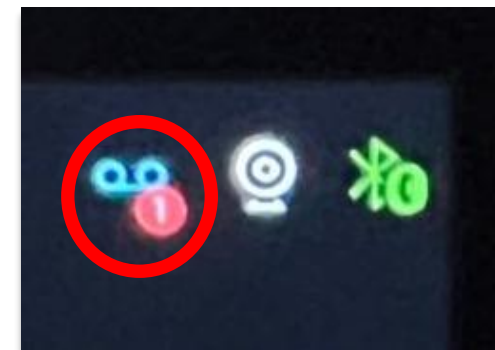

# Call Functions - Making a call

- Pick up the **Handset** or press the **Speakerphone** button, then dial the number.  
*No need to press a "line" button or dial an access code for an outside line.*
- After dialing, the phone will briefly pause, giving you time to delete and reenter a number if needed.
- To place the call immediately, press the "Call" softkey or the # key.
- To use a Headset, follow the same steps, but make sure the Headset button is selected (it usually lights green when enabled).

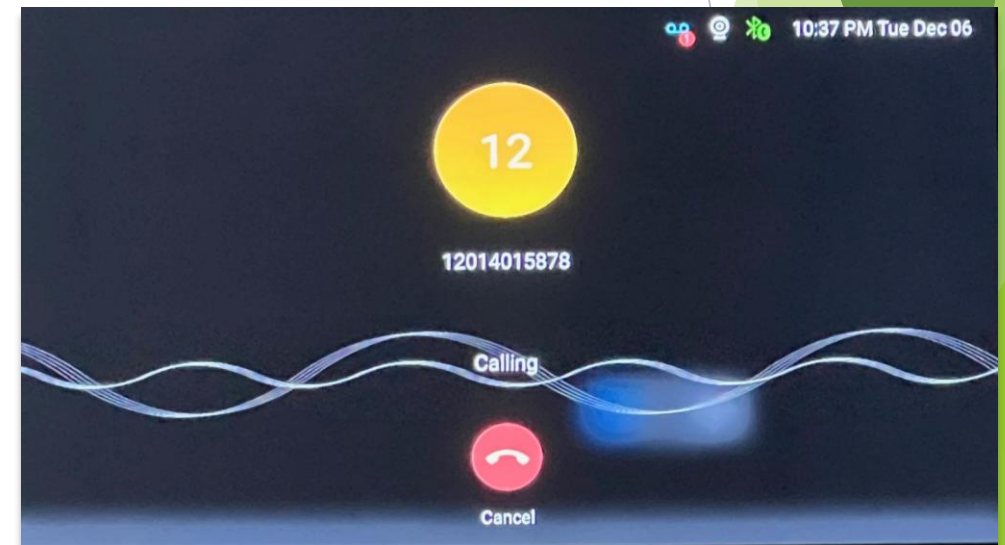
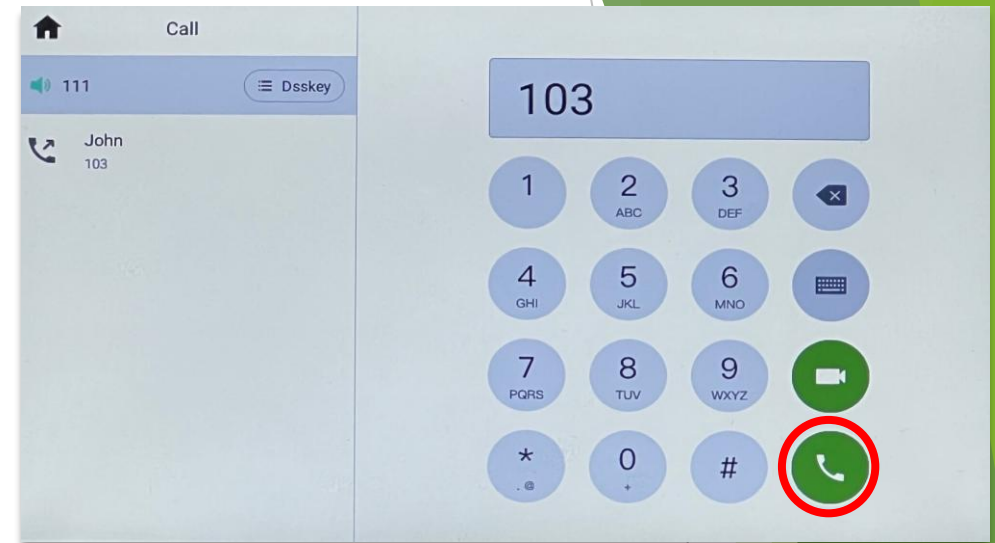

# Call Functions - Hold

## Call Hold

- Press the **Hold** button or the “**Hold**” softkey to place a caller on hold.
- To resume the call, press the **Hold** button or the “**Hold**” softkey again.

**NOTE:** The **Hold** feature is for temporarily holding **your call only**. It is **not** intended for moving a call to another phone or location. For that, use the **Park** feature (see next page).

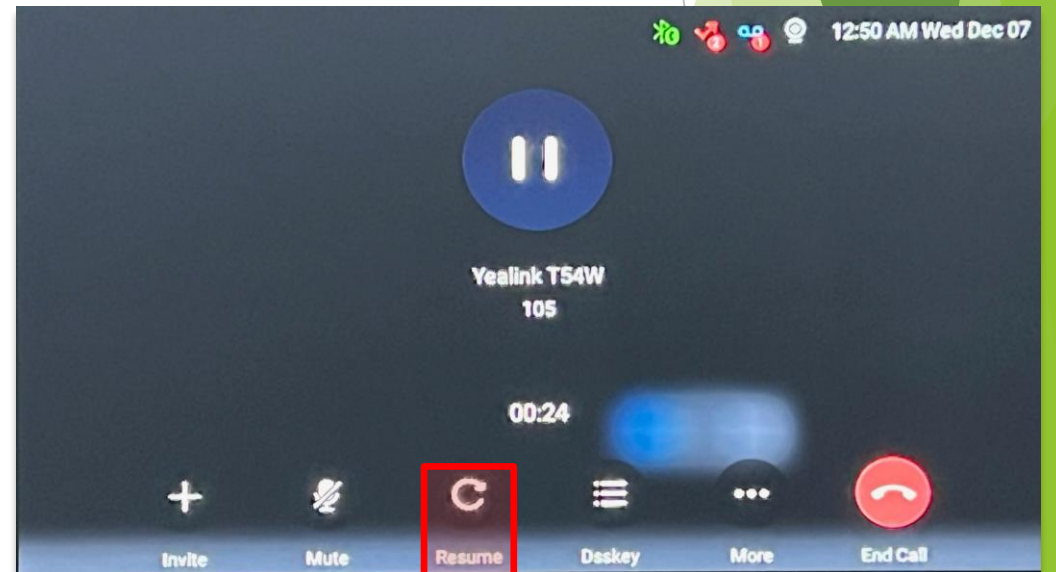
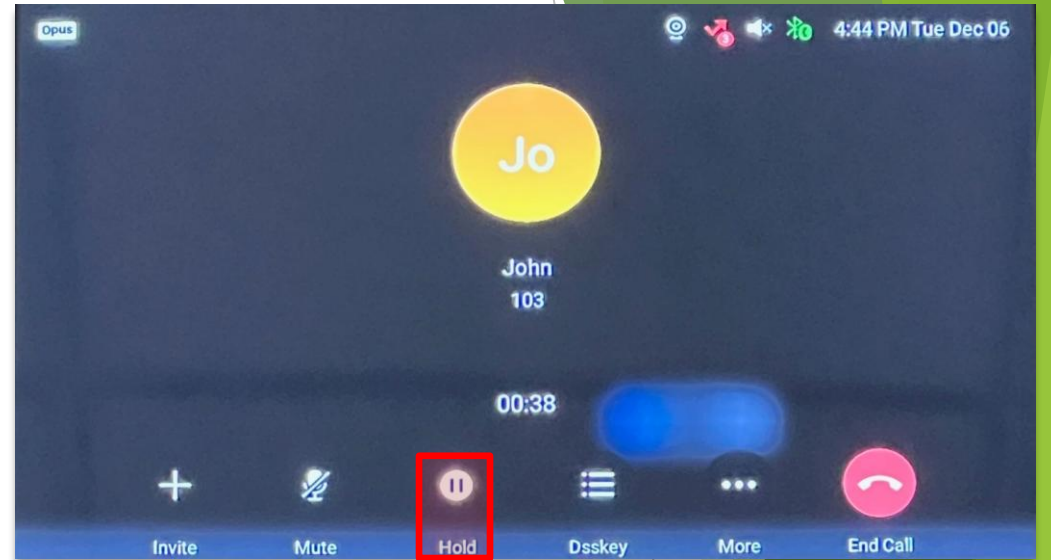

# Call Functions - Park/UnPark Calls

## Using Shared Park (SP1 / SP2)

The **Shared Park** feature allows you to place a call on *system hold* so it can be retrieved from **any phone** in the system.

### Steps to Park a Call:

- While on the call, press the **SP1** button.

The button will change from **green** to **red**, indicating the call is parked.

**!** All phones with the **SP1** button will also light up **red**.

- Page or call the intended recipient to notify them of the parked call (e.g., “Call parked on SP1”).
- To retrieve the call, press the **red SP1** button.

The button will turn back to **green**, meaning the call is picked up and the park location is free again.

**!** Use **SP2** in the same way if **SP1** is already in use.

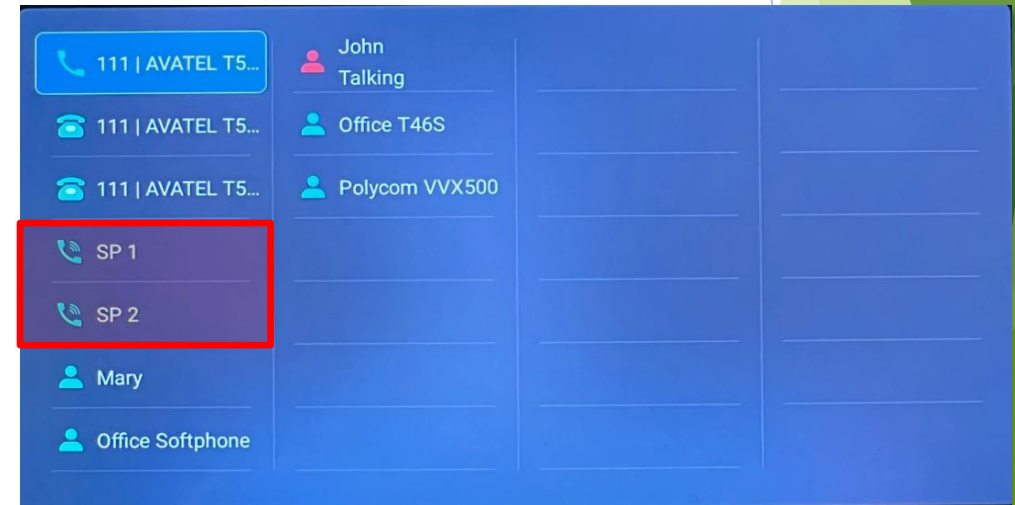
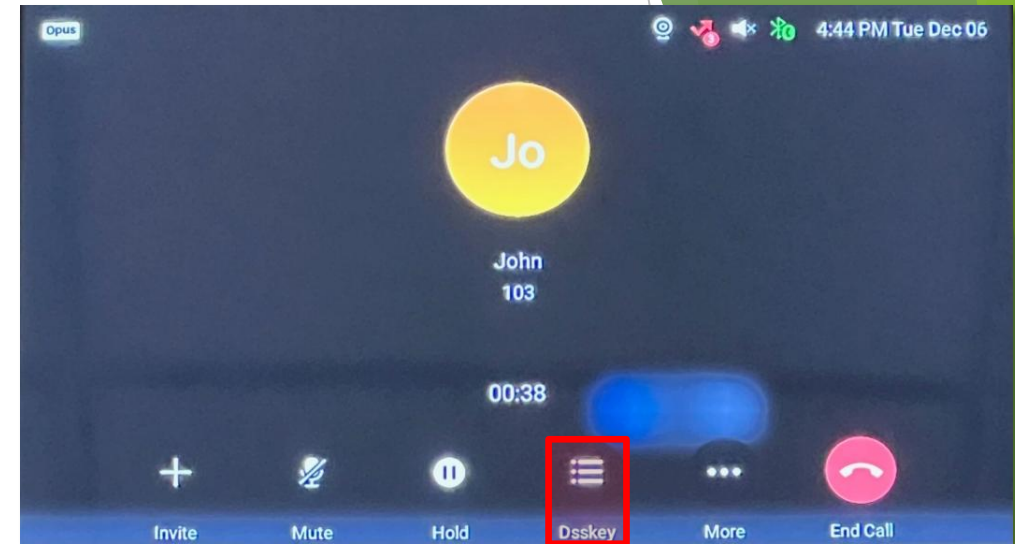

# Call Functions – Transfer using DSS Keys

1

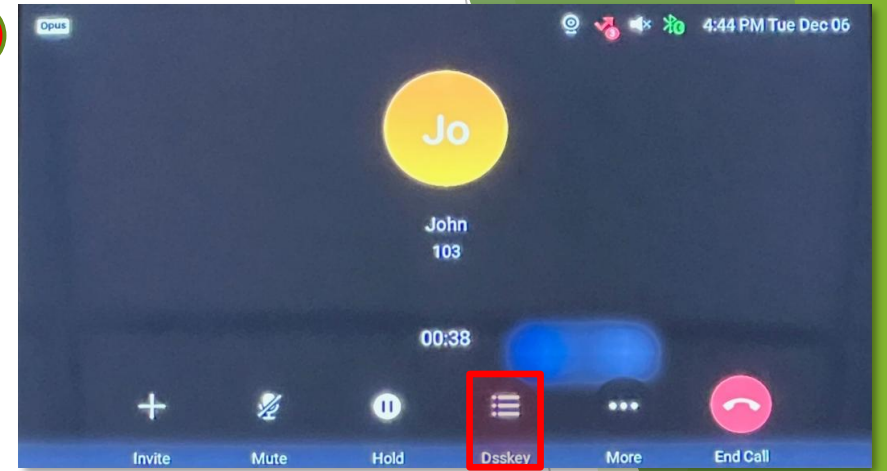

- To perform a blind transfer, press the “DSSkey” and select the extension you wish to transfer to.

3

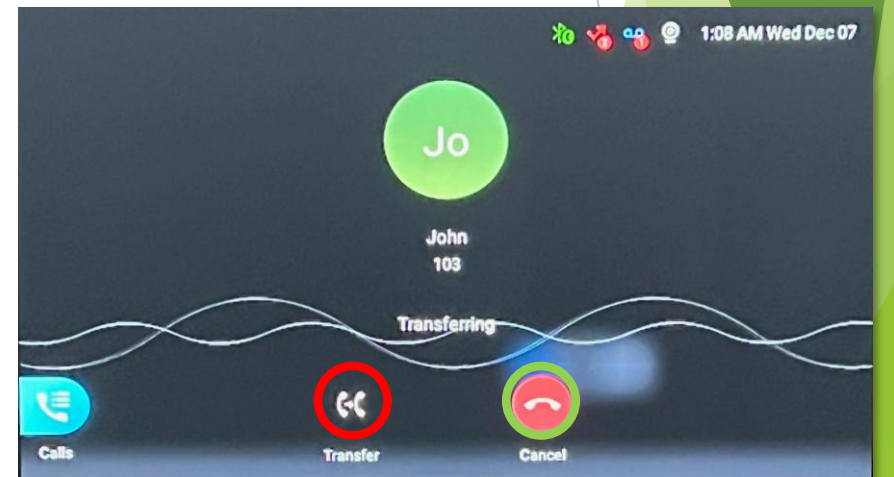

- To complete the transfer, simply hang up or press the “Transfer” softkey.
- OR** If you wish to announce the call, simply stay on the line and wait for the party to answer. If they decline the call, press the “Cancel” softkey.

2

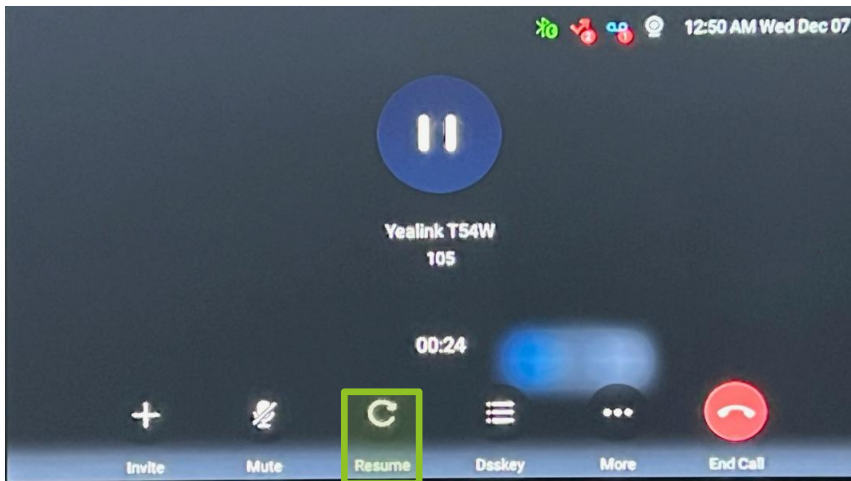
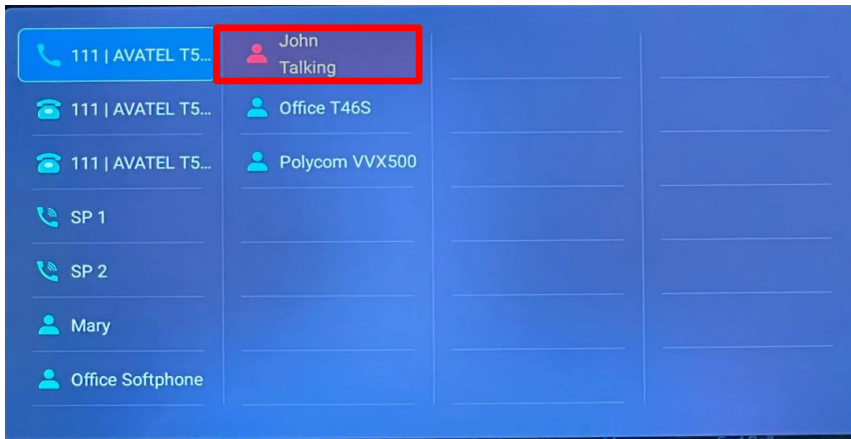

- Press the “Resume” softkey to return to the caller.

4

# Call Functions – Using the Transfer Button



- Press the “Transfer” Button

- Blind Transfer: Sends the call to another extension and immediately hangs up.
- Assisted Transfer: Sends the call to another extension and allows you to communicate with the user, while the call is on hold.

2

- Dial the extension number and press the “Blind” or “Assisted” transfer softkeys.



- OR you can press the “Dsskey” and select an extension.

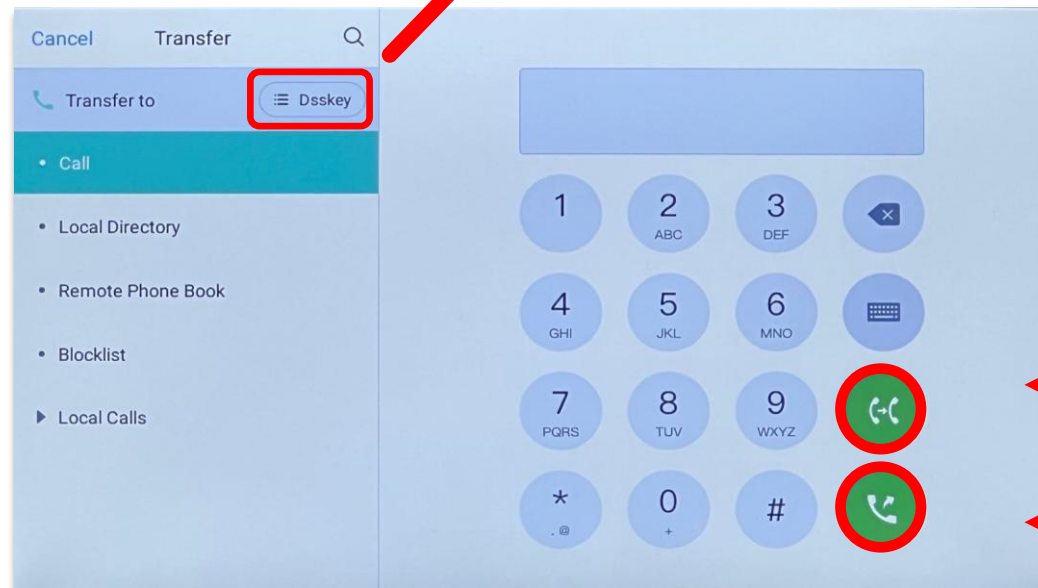

▪ Assisted Transfer

▪ Blind Transfer

# Other Functions - Call History & Redial

- The History softkey gives you access to all calls that reached your extension as well as calls that were made from your phone. There are 5 categories accessible on the left panel. Pressing the History softkey reveals the following categories:
- Local Calls- *A filtered list of internal calls made or received on the phone*
- Missed Calls - *A filtered list of calls unanswered on the phone*
- Placed Calls - *A filtered list of calls made from the phone. This can also be accessed by pressing the Redial button.*
- Received Calls - *A filtered list of all calls received and answered on the phone*
- Forwarded Calls - *A filtered list of all calls received and forwarded to another destination. This field will only be populated when call forwarding is active on the extension.*

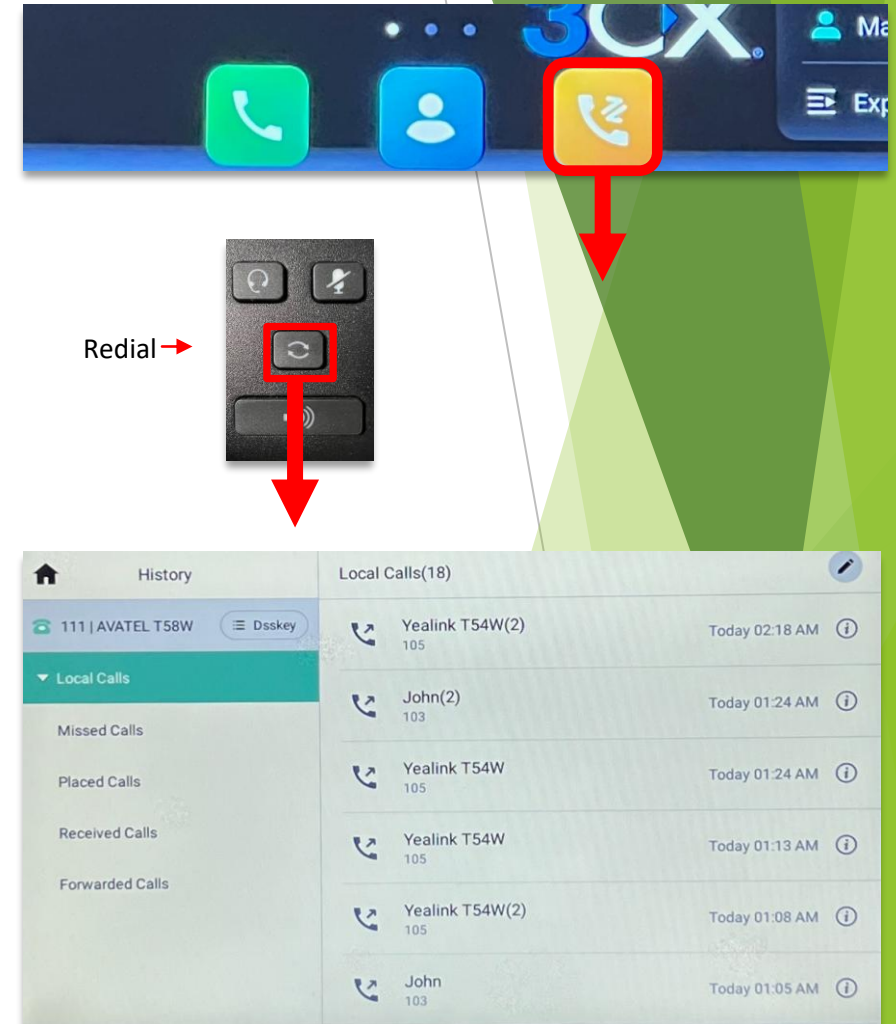

# Other Functions - Call History Features

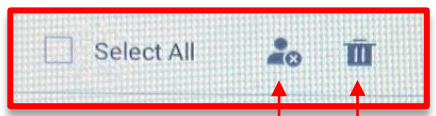

Add to Blocklist Delete

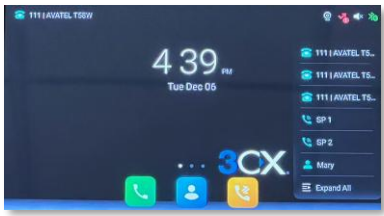
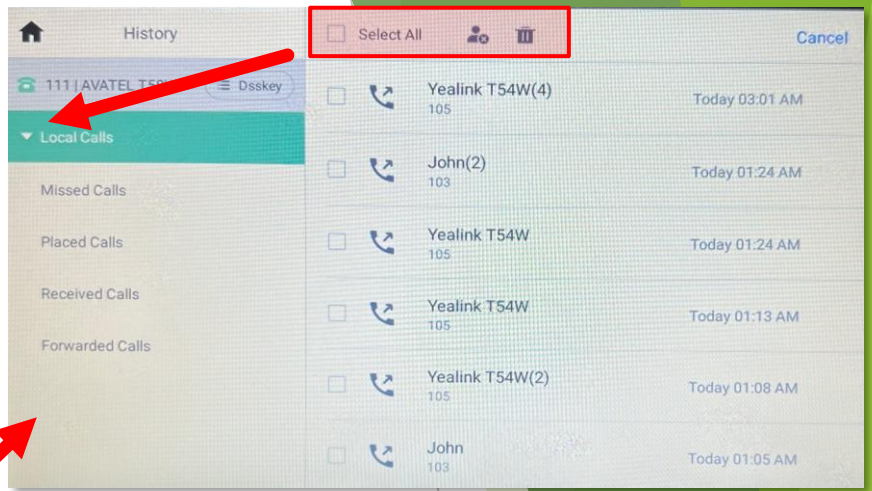

Return to Home Screen

Press the icon to ring back the caller.

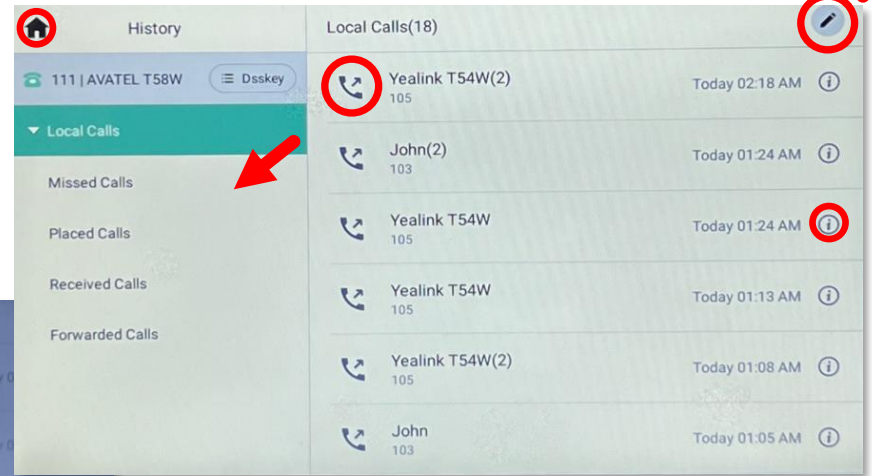

Press the icon for the option to delete entries or add them to the blocklist. The blocklist will block callers from ringing your extension.

Press the icon for call details

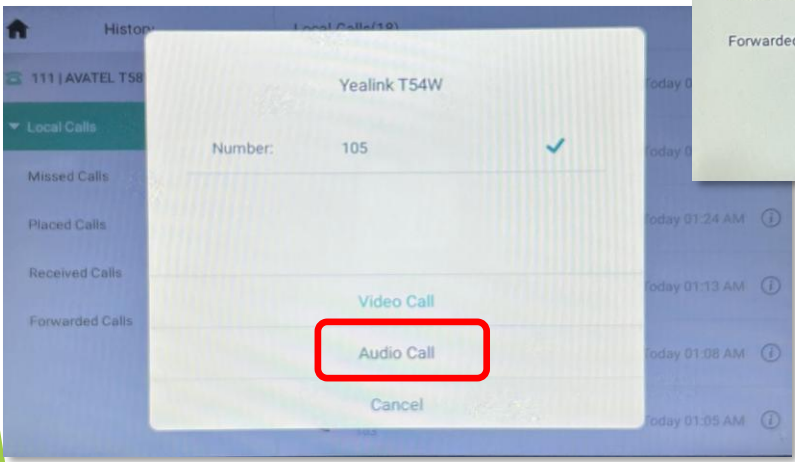

Press "Audio Call" to place the call.

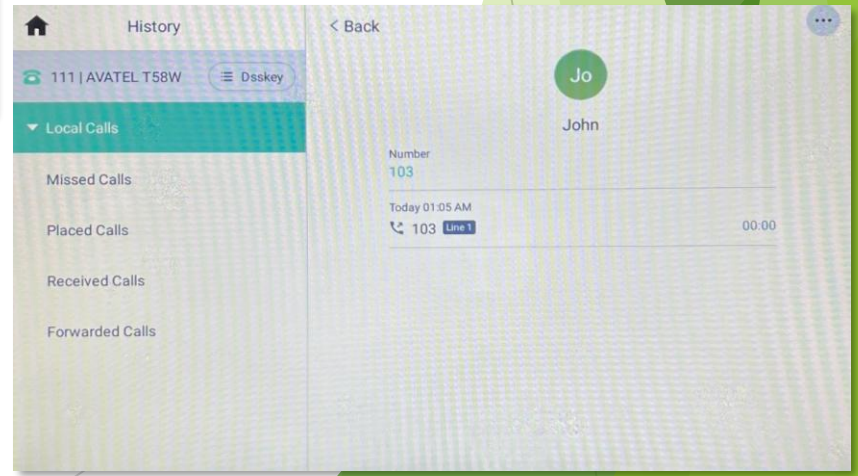

# Other Functions - Call Details

- Add- *Adds a contact to your local directory*
- Edit before calling- *Allows you to edit the contact information*
- Blocklist- *Allows you to add a contact to your blocklist*
- Delete- *Allows you to delete the contact*

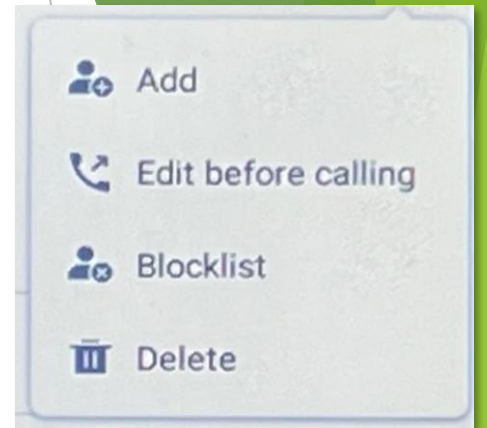
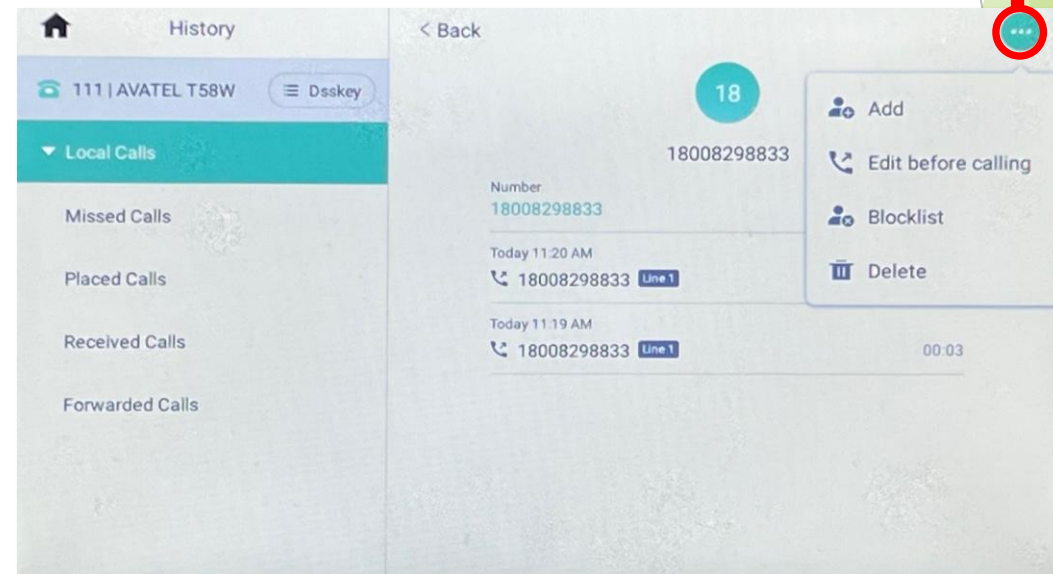
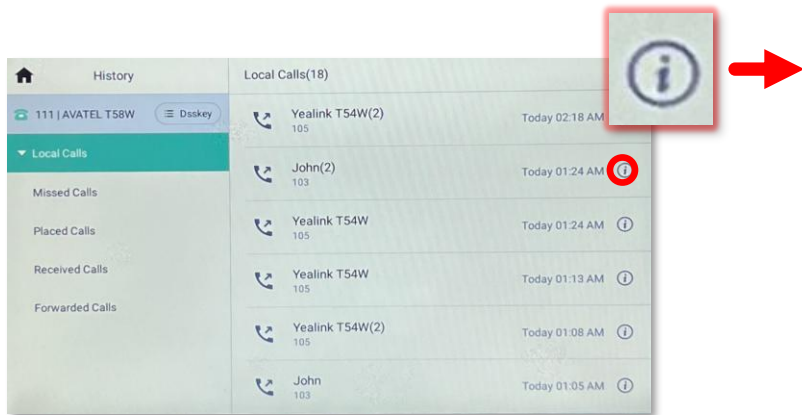

## Other Functions – Remote Phone Book

- The Remote Phone Book softkey gives you access to all internal contacts as well as personal contacts saved on your phone. There are 3 categories accessible on the left panel:
- **Local Directory** - *This selection gives you access to all personal contacts saved on your phone.*
- **Remote Phone Book** - *This selection gives you access to all internal contacts on the system.*
- **Blocklist** - *This selection gives you access to all blocklist entries added from your call history. You can add or delete contacts in this section.*

⚠ **Note:** Contacts saved in the **local directory** exist only on your individual phone and are **not stored in the 3CX system**. If your phone is replaced, notify the service team so your personal contacts can be transferred.

**Best Practice:** Use the **3CX Web Client** to enter company contacts. These are synced and accessible across all phones.

**TIP:** When newly added contacts are added in the Webclient, press 3CX Pbook -> Options -> UPDATE. This will ensure you have the latest updated directory.

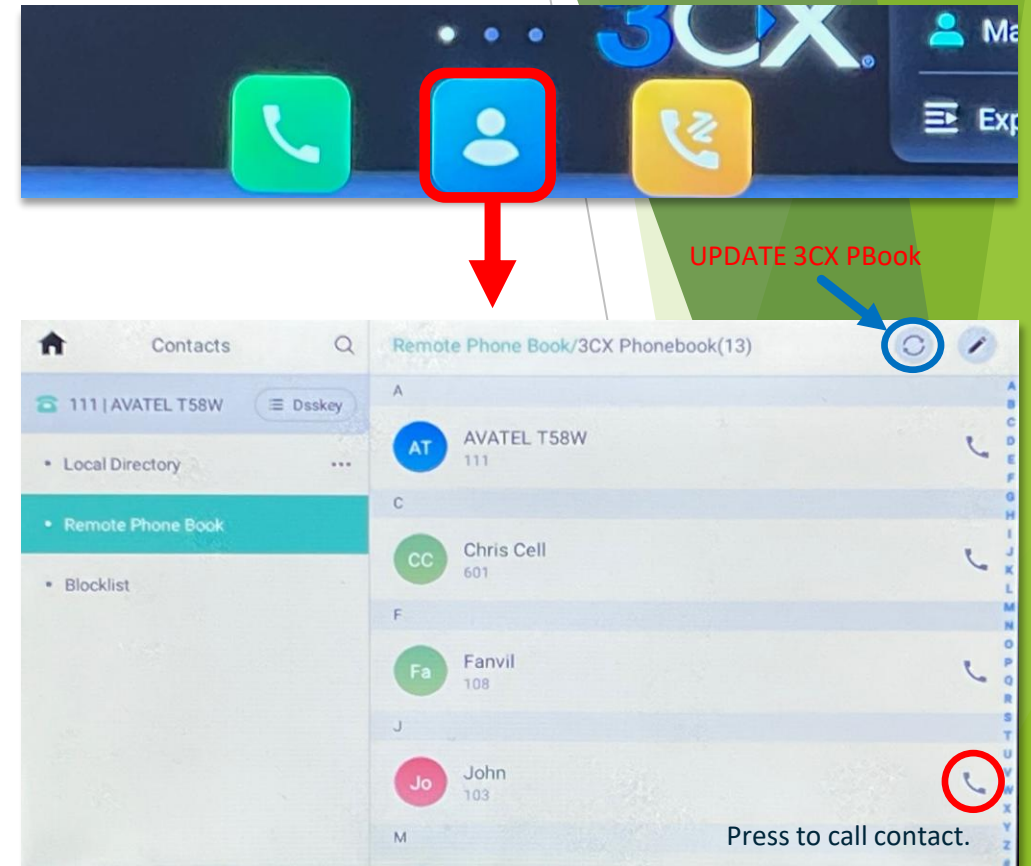

# Other Functions - Voicemail

- Pressing the “Voicemail” button or dialing the *voicemail access code* (see below) will give you access to your mailbox and the voicemail system. If you have voicemail, the system will begin playing your messages automatically. You can control and access different parameters of the voicemail by pressing the following digits at any time:

***NOTE: The voicemail system will prompt additional options once you select a section. Please follow the prompts after selection.***

- Press \* to play messages
- Press 1 to change profile status
- Press 4 to delete all read messages
- Press 5 to record name for the mailbox
- Press 6 to play mailbox information
- Press 7 to change mailbox pin
- Press 8 to record your greeting
- Press 9 to replay menu prompts
- Press # to exit voicemail

## Greetings

- “0” Save
- “1” Re-Record
- “2” Verify

## Play Sub-Menu

- “0” Plays next message
- “1” Plays previous message
- “2” Repeats message
- “3” Deletes message
- “4” Calls back the number
- “5” Forwards the message
- “9” Back to voicemail options
- “#” Exit Voicemail



***Voicemail Access Code:*** Dial the appropriate code that matches your system extension setup.  
**2 digit ext. “99”    3 digit ext. “999”    4 digit ext. “9999”**